

G AIR CURTAINS

AIR CURTAIN HIGH VELOCITY REMOTE FM4515 SERIES

NEW

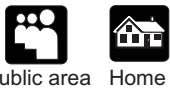

Public area Home

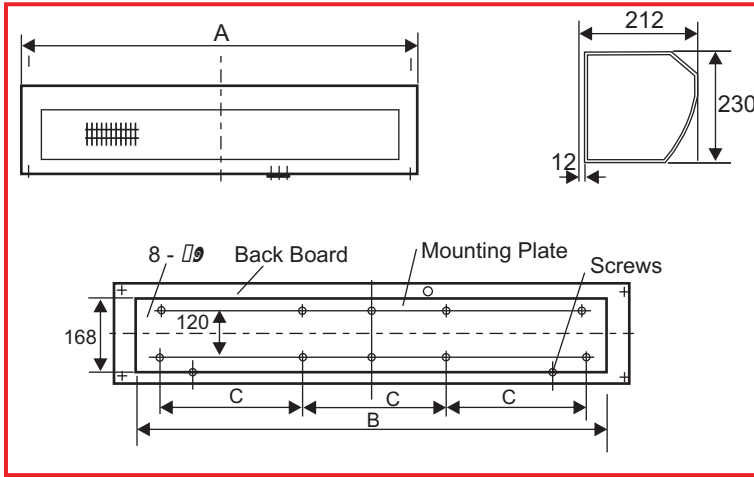

■ DIMENSIONS(MM) -

Model	A	B	C
Fm4515	1500	1450	450

■ TECHNICAL DATA

Model	Power (W)			Air Velocity (m/s)			Air Vol (m³/h)	Noise (dB)			Weight (kg)
	Hi	Med	Lo	Hi	Med	Lo		Hi	Med	Lo	
Fm4515	825	635	570	20	14.3	11.2	2375	68	65	62	25

■ FEATURES

- The Hydor series of air curtains offer an ideal solution for containing an internal conditioned (cooled or heated) environmental climates where there is a continuous exposure to the outside air
- Models are available suitable for single phase 230V 50Hz electrical connection. Airflow performances range from 1000 up to 2220 m³/hr
- The Hydor range provide the perfect solution to preventing the escape of "costly" conditioned air to the outside and preventing the un-conditioned outside air from entering
- The air curtain provides a powerful continuous stream of evenly distributed air between the outside and inside air.
- This environmental conditioning system to more easily maintain a comfortable internal climate
- **Quality motor runs for 5000 hours continuously without any defects.**
- **Maximum height is 4.0m - 4.5m**

■ CONSTRUCTION

- All Hydor air curtains embrace a stylish yet non obtrusive aesthetic to compliment many modern interior environments.
- The casings are manufactured from sheet steel and protected with a high grade ivory colour epoxy paint which provides a tough anti-corrosive finish
- All models operate with a very low noise level thanks to the balanced tangential cross-flow fan wheel which at the same time delivers a powerful uniform air stream to the surrounding environment
- Integrated into the casing are commercial grade control switches
- These enable the independent control of the fan functions (an external remote control module is available as an option - please enquire)

